

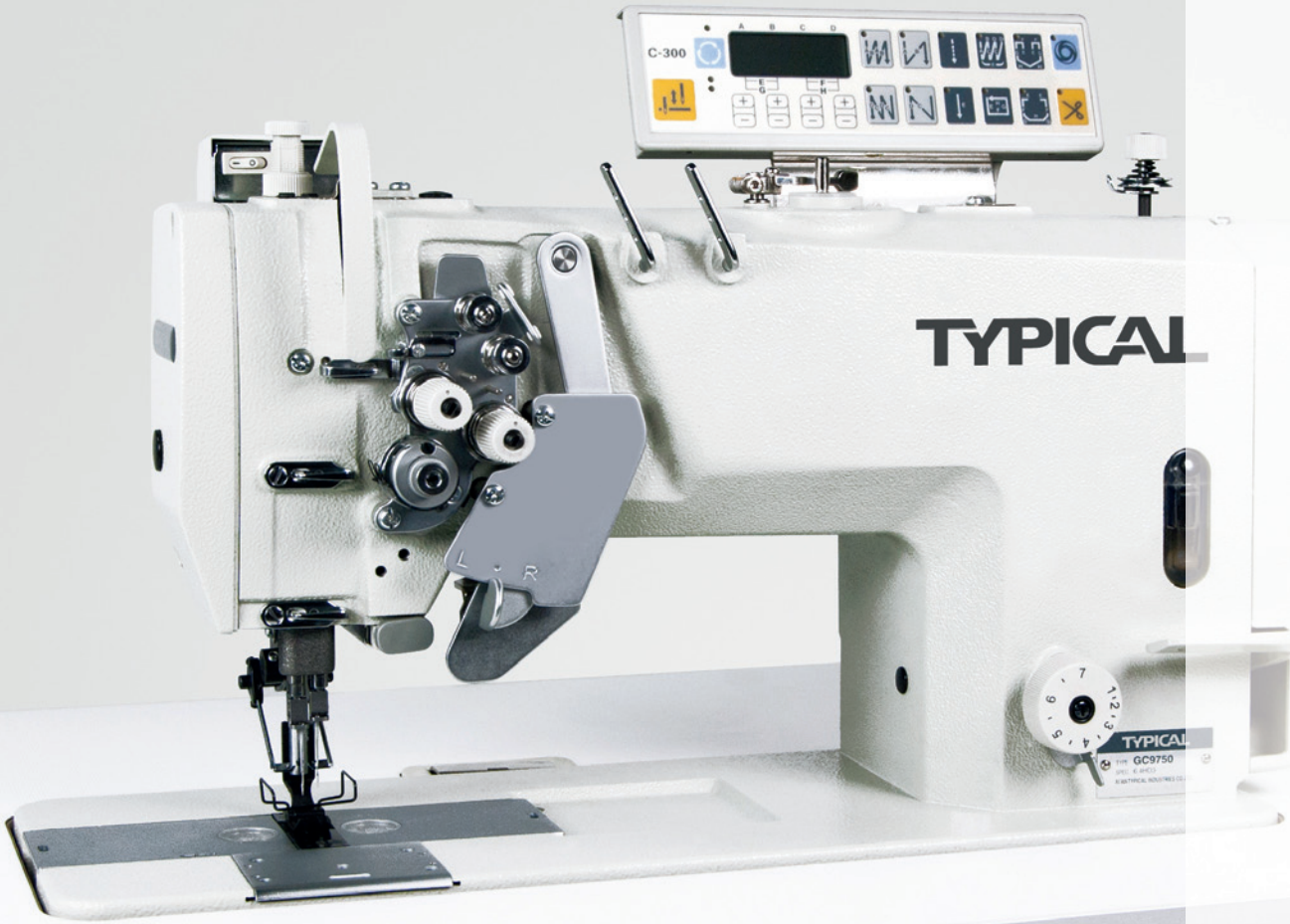

GC9SERIES



HIGH-SPEED DOUBLE-NEEDLE LOCKSTITCH SEWING MACHINE
HOCHLEISTUNGS-, 2-NADEL DOPPELSTEPSTICH NÄHMASCHINE

TYPICAL



Features & Benefits

- Drop feed and needle feed
- Modern Direct-Drive on all -MD3 and -HD3 machines for low noise and low vibrations
- GC9720, GC9750:
Large hook for higher bobbin capacity (Jeans, Workwear, etc.)
- GC9420, GC9450:
Small hook for smooth seams on thin material (shirt, blouses, etc.)
- GC9750, GC9450: split needle bar for corner sewing (1)
- Adjustable thread guides to optimize seam quality (2)
- Hook fine adjustment for easier needle distance settings (3)

Standard Equipment on all -MD3 and HD3 machines:

- Automatic thread cutter
- Automatic thread wiper
- Automatic back tacking device
- Option: Automatic presser foot lifter

Merkmale & Vorteile

- Untertransport und Nadeltransport
- Moderner Direct-Drive an allen -MD3 und HD3 Maschinen zur Geräusch- und Vibrationsreduzierung
- GC9720, GC9750:
Großer Greifer für mehr Spulenfadencapazität (Jeans, Arbeitsbekleidung, ...)
- GC9420, GC9450:
Kleiner Greifer für glatte Nähte an feinen Materialien (Hemden, Blusen, ...)
- GC9750, GC9450: ausschaltbare Nadelstangen für Eckennähen (1)
- Einstellbare Fadenführungen zur Optimierung der Nahtqualität (2)
- Feineinstellung der Greiferböcke vereinfacht das Justieren des Greiferabstandes zur Nadel (3)

Standard Ausstattung aller -MD3 und -HD3 Maschinen:

- Automatischer Fadenabschneider
- Automatischer Fadenwischer
- Automatische Verriegelungseinrichtung
- Option: Automatische Nähfußlüftung

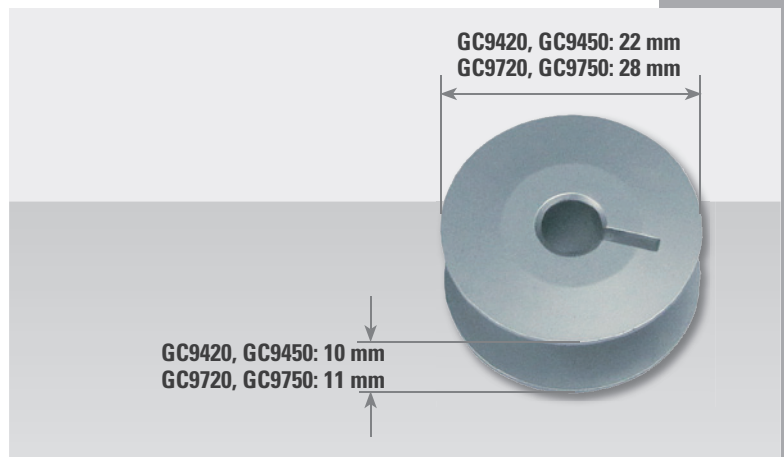
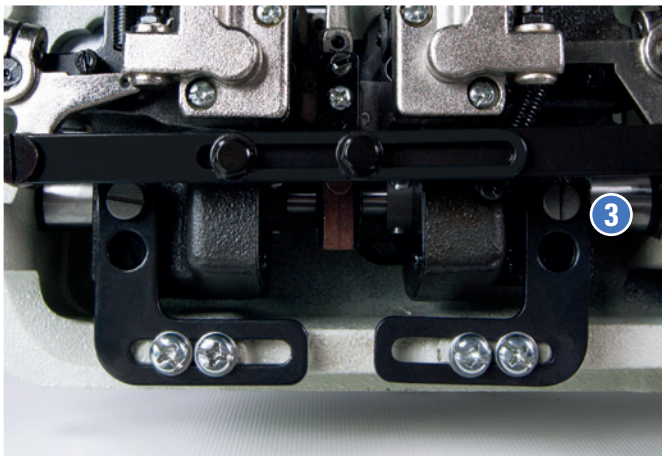

GC9SERIES

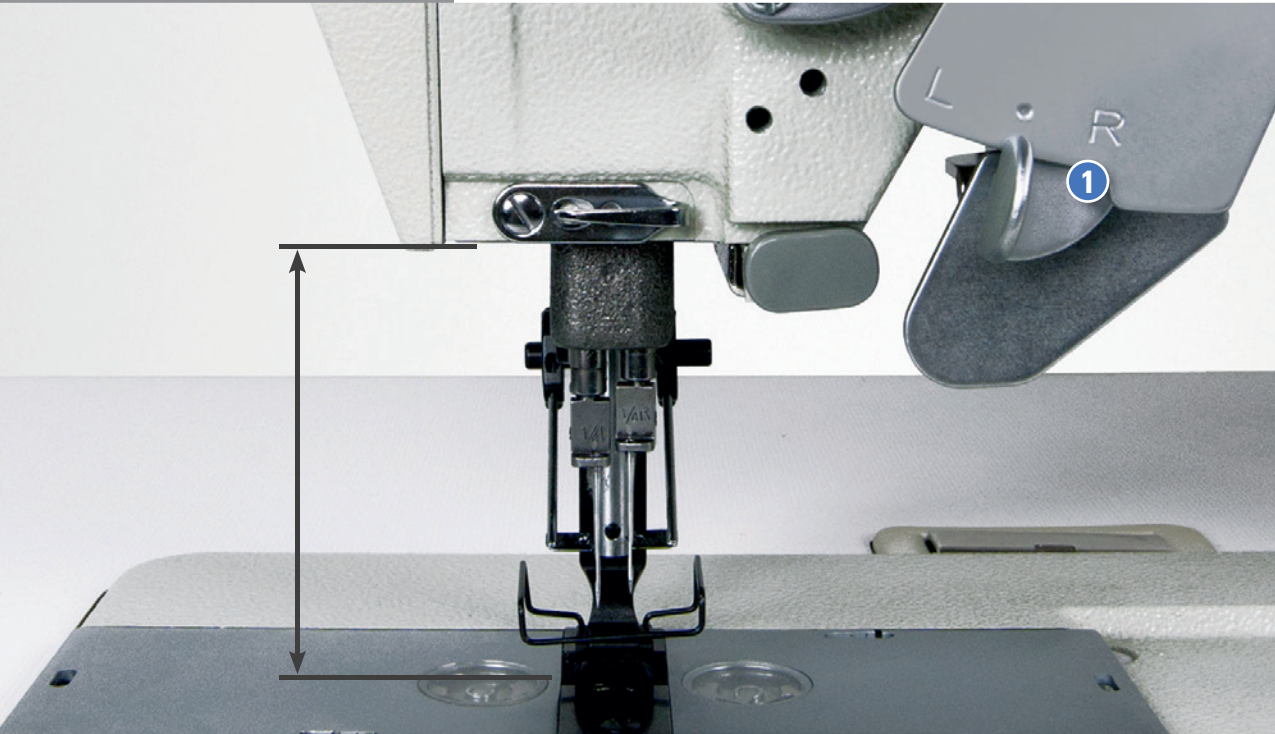

HIGH-SPEED DOUBLE-NEEDLE LOCKSTITCH SEWING MACHINE
HOCHLEISTUNGS-, 2-NADEL DOPPELSTEPSTICH NÄHMASCHINE

Technical Data

- Stitch type 2 x 301
- Max. sewing speed 4,000 spm. (GC9420)
- Max. stitch length 7 mm (GC9750, GC9720)
- Max. fabric clearance 13 mm with knee lever

Clearance under the arm

- 264x120 mm

Fully automatic enclosed lubrication system

Carton dimensions and gross weights for sewing head GC9720, GC9750, GC9420, GC9450:

73x32x67 cm, 54 kg

GC9720-/GC9750-HD3, GC9420-/ GC9450-MD3:

73x32x67 cm, 61 kg

Technische Daten

- Stichtyp 2 x 301
- Max. Nähgeschwindigkeit 4.000 Stiche / Minute (GC9420)
- Max. Stichlänge 7 mm (GC9750, GC9720)
- Max. Durchgangsraum unter dem Nähfuß 13 mm

Durchgangsraum im Nähmaschinenarm

- 264x120 mm

Vollautomatisches geschlossenes Schmiersystem

Kartonmaße und Brutto-Gewichte für Nähkopf GC9720, GC9750, GC9420, GC9450:

73x32x67 cm, 54 kg

GC9720-/GC9750-HD3, GC9420-/ GC9450-MD3:

73x32x67 cm, 61 kg

GC9 SERIES

HIGH-SPEED DOUBLE-NEEDLE LOCKSTITCH SEWING MACHINE HOCHLEISTUNGS-, 2-NADEL DOPPELSTEPSTICH NÄHMASCHINE



9720-	M	2x301	3,000	•	7	134/DPx5 75-100	33.4	L	7/13	6.4**						M/H
	H	2x301	3,000	•	7	134/DPx5 90-140	33.4	L	7/13	6.4**						H
	MD3	2x301	3,000	•	7	134/DPx5 75-100	33.4	L	7/13	6.4**		•	•	•	◦	M/H
	HD3	2x301	3,000	•	7	134/DPx5 90-140	33.4	L	7/13	6.4**		•	•	•	◦	H
9750-	M	2x301	3,000	•	7	134/DPx5 75-100	33.4	L	7/13	6.4**	•					M/H
	H	2x301	3,000	•	7	134/DPx5 90-140	33.4	L	7/13	6.4**	•					H
	MD3	2x301	3,000	•	7	134/DPx5 75-100	33.4	L	7/13	6.4**	•	•	•	•	◦	M/H
	HD3	2x301	3,000	•	7	134/DPx5 90-140	33.4	L	7/13	6.4**	•	•	•	•	◦	H
9420-	M	2x301	4,000	•	4	134/DPx5 75-100	33.4	S	7/13	6.4**						L/M
	H	2x301	3,000	•	5	134/DPx5 90-140	33.4	S	7/13	6.4**						M
	MD3	2x301	4,000	•	4	134/DPx5 75-100	33.4	S	7/13	6.4**		•	•	•	◦	L/M
	HD3	2x301	3,000	•	5	134/DPx5 90-140	33.4	S	7/13	6.4**		•	•	•	◦	M
9450-	M	2x301	3,000	•	5	134/DPx5 75-100	33.4	S	7/13	6.4**	•					L/M
	H	2x301	3,000	•	5	134/DPx5 90-140	33.4	S	7/13	6.4**	•					M
	MD3	2x301	3,000	•	5	134/DPx5 75-100	33.4	S	7/13	6.4**	•	•	•	•	◦	L/M
	HD3	2x301	3,000	•	5	134/DPx5 90-140	33.4	S	7/13	6.4**	•	•	•	•	◦	M

◦ Option

Specifications can differ depending on model.
Angaben können je nach Ausführung abweichen.

** Other needle distances on request.
Andere Nadelabstände auf Anfrage.



XI'AN TYPICAL EUROPE GmbH

Hertelsbrunnenring 9
D-67657 Kaiserslautern
Tel.: +49 (0)631 316019-0
Fax: +49 (0)631 316019-11

E-mail: sales@typical-europe.com
www.typical-europe.com