

HVP - 20 SERIES AC SERVO MOTOR



COMPACT
BUT
POWERFUL



F - 10 MINI PANEL



CERT.NO.3A1Y004-03

Features

1. Highly accurate positioning.
2. Multi- Positioning mode.
3. Low noise 、 low vibration and low power consumption.
4. Software / Hardware 2-way protection system.
5. Solenoid over current protector.
6. Switching power supply system. (160V~280V AC)
7. Powerful parameter system, easy adjustment and upgradable.
8. Self-Diagnostic function.
9. 3 ϕ 380V available.



Synchronizer



800 Series



500 Series

AC Motor

- 500W for general machine head.
- 600W good for chain-stitch machine
- 750W for special or heavy duty machine head.

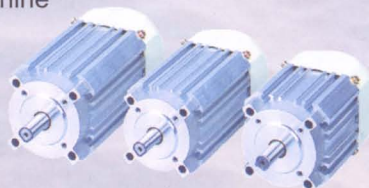

750W

600W

500W

Mini - Operation

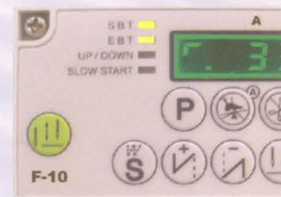

- Miniature design.
- Stitches are clearly displayed on the display.
- Start / End back tacking can be set.
- Pattern sewing can be set in 1~25.
- Repeat Bar tacking can be set in 1~25.
- Panel function setting : trimmer ca...
- Parameter setting function available.
- Built-in EEPROM, save and backu...

AC SERVO MOTOR

Mounting Bracket

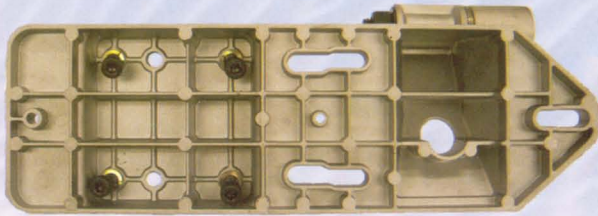

For under table



For direct drive

Patent pending

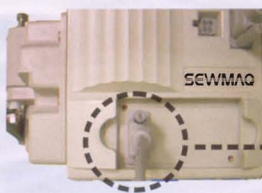

Extension cable for remote control
F-10 Mini

Operation Box (D-sub)

C-60



C-60 --For Standard Mounting
C-60B1 --For Brother Built-in

C-60B1

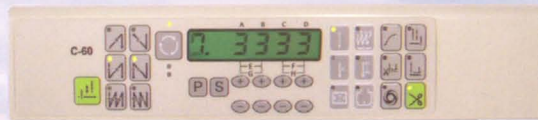

Box



LCD.

in 1~15 stitches.

stitches per section, 15 sections Max.

15 stitches, 15 sections Max.

cel · needle up/down, slow start...etc

.

your setting.

- Stitches are clearly displayed on the LCD.
- Start/End back tacking can be set in 1~15 stitches.
- Pattern sewing can be set in 1~99 stitches.
- LCD back light.
- Parameter setting is available.
- Linkable to PC
- Counter/Timer function
- Built-in EEPROM, save and backup your setting.

Specification

Function	HVP-20-3	HVP-20-4
Motor Output	500W-5000 rpm.	
	600W-3500 rpm.	
	750W-2500 rpm.	
Power Voltage Range	Single Phase : 100~120V , 200~240V	
	Three Phase : 200~240V , 380~400V	
Pulley Size Available	65 , 75 , 85 mm	
Needle UP / DOWN	★	★
Soft Start	★	★
Presser Foot Lifting	★	★
Trimmer / Wiper	★	★
Automatic Back-Tacking	★	★
Reverse at Stop	★	★
Power Transistor Protection	★	★
Power Module Protection	★	★
Input Signal Port	4	5
Solenoid Signal Output Port	5	6
Edge Sensor Input Port	1	1
Gross Weight	500W:5.2 / 600W:5.6 / 750W:6.2 kg	

Dimension

Control box

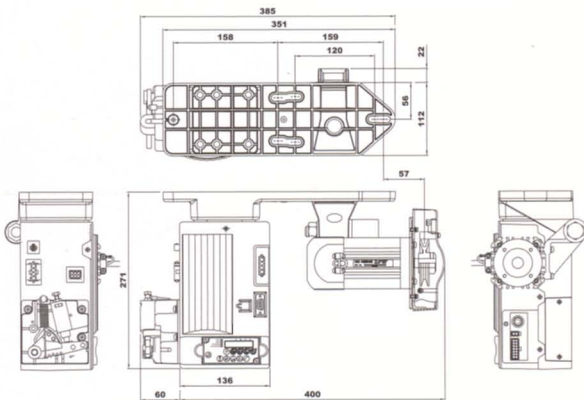

Motor

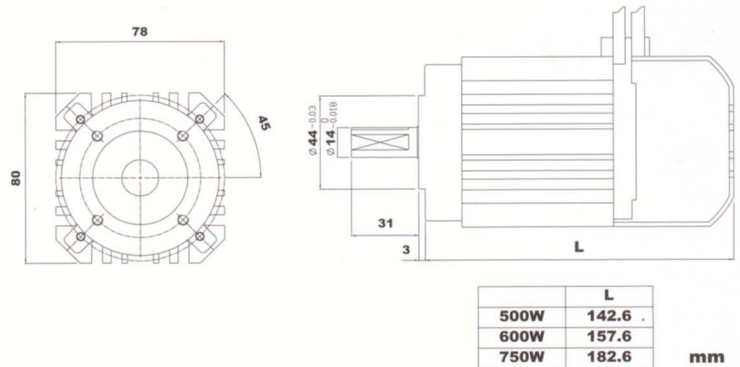

Model Code

Control box

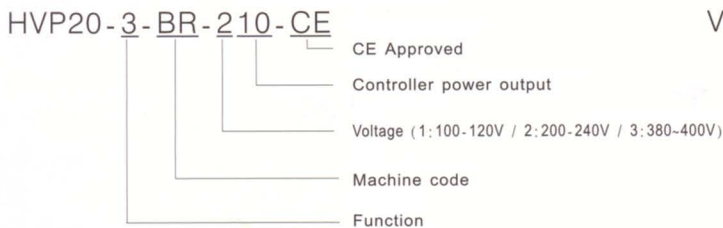

Motor

