



BH 1000

Global[®] BH 1000 - Eyelet buttonhole machine

TECHNICAL SPECIFICATIONS

Machine speed*
1750 spm

Stitch type
401

Number of needles
1

Buttonhole length
10 - 32 mm
cam related

Feed type
intermittent cam

Clamplift
10 mm

Needle type
501 / 1807 D

BH 1000 – Two thread chainstitch eyelet buttonhole machine, easily adjustable from “cut before” to “cut after” buttonholes, with or without fly bar. Suitable for tailored clothing, outerwear, vests and jeans. Supplied with 4 interchangeable cams, 2 types of knives (cut before and cut after) and 4 cutting blocks. Standard delivered with following sizes: 13, 16, 18 and 22 mm. Equipped with automatic needle thread trimmer.

BH 1000 – Máquina de 2 hilos en cadeneta para ojales, fácilmente ajustable desde “corte anterior” a “corte posterior”, con o sin barra levadiza. Adecuada para ropa hecha a medida, ropa para exteriores, chalecos y vaqueros. Se suministra con 4 levas intercambiables, 2 tipos de cuchillas (corte anterior y corte posterior) y 4 bloques de corte. El modelo estándar se entrega en las siguientes medidas : 13, 16, 18 y 22 mm. Corta hilos superior automático.

BH 1000 – 2 fädige Knopflochmaschine, umstellbar als Vorschneider und Nachschneider, mit 4 verschiedenen Kurvenscheiben, 2 Messertypen und 4 Messerblocks. Standardlängen 13, 16, 18, und 22mm Einsatzgebiete: Damen- und Herren Oberbekleidung, Jeans u.s.w. Ausgestattet mit automatischen Nadelfaden - Abschneider.

BH 1000 – Machine boutonnière à oeillet point de chaînette 2 fils, modifiable facilement de « coupe avant » en « coupe après », avec ou sans arrêt en pointe. Recommandée pour vêtement de tailleur, pardessus, veste et jeans. Livré avec 4 cames interchangeables, 2 types de couteaux (coupe avant/coupe après) et 4 blocs de coupe. Livraison standard dans les dimensions suivantes: 13, 16, 18 et 22 mm. Coupe automatique du fil d' aiguille.

Features

Semi-Automatic Lubrication System uses drip oil wicks to carry oil to the critical parts of the machine.

Oil Level Indicator warns the operator or mechanic when the machine is low on oil, preventing machine from severe damage which can be caused by running the machine without enough oil.





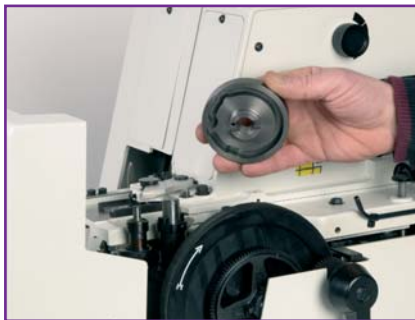

Revolutionary Stop Motion contributes to improved product quality by virtually eliminating sewing defects such as "double stops". The roller activation ensures one full revolution to absorb the momentum every time, prolonging the life of the machine and increasing reliability.



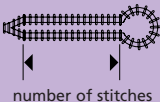

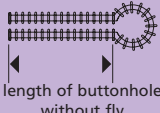
Pattern Cam Replacement allows rapid changes in buttonhole styles. Buttonhole size, eye style (eye, no eye) and end finishing (open end, flybar) can be changed by selecting one of the cams.

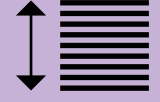

The cams of the BH 1000 are easily interchangeable; just remove and replace

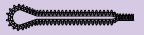
Specifications

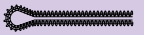
 needle system	1807-D 501
 number of stitches	per inch 15 - 40 per 10 mm 6 - 16
 stitch width	inch $\frac{5}{64}$ - $\frac{9}{64}$ mm 2.0 - 3.5
 length of buttonhole without fly	inch $\frac{1}{2}$ - $1\frac{1}{2}$ mm 12.5 - 40
 length of buttonhole with fly	inch $\frac{13}{32}$ - $1\frac{1}{4}$ mm 10 - 32
 max presserfoot lift	inch $\frac{13}{32}$ mm 10
 max. thickness of sewn work	inch $\frac{1}{4}$ mm 6
 needle threadtrimmer	•
 max. speed*	Up to spm 1750
* Max. speed depends of type of operation and/or materials to be sewn	

17 available cams suitable for BH 1000 type					
					
mm	inches	mm	inches	mm	mm
3.5 x 13*	$\frac{9}{64} \times \frac{1}{2}$	0 x 10	$0 \times \frac{13}{32}$	3.5 x min. 12.5 max. 40	0 x min. 12.5 max. 40
3.5 x 16*	$\frac{9}{64} \times \frac{5}{8}$	0 x 13	$0 \times \frac{1}{2}$		
3.5 x 19*	$\frac{9}{64} \times \frac{3}{4}$	0 x 16	$0 \times \frac{5}{8}$	inches inches	
3.5 x 22*	$\frac{9}{64} \times \frac{7}{8}$	0 x 19	$0 \times \frac{3}{4}$	3.5 x min. 12.5 max. 40	0 x min. 12.5 max. 40
3.5 x 26	$\frac{9}{64} \times 1$	0 x 22	$0 \times \frac{7}{8}$		
3.5 x 29	$\frac{9}{64} \times 1\frac{1}{8}$	0 x 26	0 x 1	* Standard with each BH-1000	
3.5 x 32	$\frac{9}{64} \times 1\frac{1}{4}$	0 x 29	$0 \times 1\frac{1}{8}$		
		0 x 32	$0 \times 1\frac{1}{4}$		

Standard delivered with

- Heavy duty table top (5 cm in thickness) • metal stand
- 3/4 hp clutch motors, any voltage, cycle or phase

★ Max. sewing speed (in spm.) depends on type of operation and/or materials to be sewn.

The GLOBAL® Selection is brought to you by:

GLOBAL® is a trademark of the Global International Corporation, the people that carefully organize the supply of spareparts before they launch each product.

When ordering parts please specify:
 1 machine model
 2 part numbers